

**Aviation Fabricators  
805 North Fourth Street  
Clinton MO 64735**

Document No: AF-514  
Revision: (H)  
Date: February 9, 2024

## ***INSTRUCTIONS FOR CONTINUED AIRWORTHINESS***

For

Window Shade Installation

**Document No.: AF-514**

**Revision "H"**

**Revision Date: 02-09-24**

**Applicable to:**

**Beechcraft C90, C90A, C90GT, C90GTi, E90, F90,  
200, 200C, 200CT, 200T,  
B200, B200C, B200CT, B200T,  
B200GT, and B200CGT Series Aircraft**

**Modified by FAA STC SA01672WI**

The information in the Instruction for Continued Airworthiness is FAA accepted material and complies with 14 CFR 23.1529, Instructions for Continued Airworthiness. It supersedes or adds to that provided in the Maintenance Manual for the Beechcraft 90 & 200 Series Aircraft, only where covered in the items contained herein. For limitations and procedures not contained in the Supplement, consult the Component Maintenance Manual, or other approved airplane data.

## **REVISION PAGE**

Document Title: Instructions for Continued Airworthiness

Prepared By: Todd Pogue

Updates to the ICA will be made by Aviation Fabricators Inc. Updates will be listed in the log of revisions and the effective pages will be listed below.

<b>Log of Revisions</b>				
<b>REV. NO.</b>	<b>EFFECTED PAGE(S)</b>	<b>DESCRIPTION</b>	<b>DATE</b>	<b>APPROVED BY</b>
IR	All	Initial Release	01-10-11	G.R. Lowe III
A	11	*Updated Section 10 to latest format, page 11	11-12-12	G.R. Lowe III
B	6 & 7	*Updated hardware p/n's shown in Figure 1.0A & B, pages 6 & 7	01-20-15	Jeffrey R. Lowe
C	1,2,5,&6	*Added new assembly p/n 32-0438 to ICA	10-21-15	G.R. Lowe III
D	All	*Added models C90, C90A, C90GT, C90GTi, E90, & F90	02-07-17	Jeffrey R. Lowe
E	7	*Updated installation view with new spacer added	09-13-17	Jeffrey R. Lowe
F	1,2,5,&6	*Added new assembly p/n 32-0497 to ICA	01-19-18	Jeffrey R. Lowe
G	All	*Removed all specific P/N callouts and referred to STC Data List AF-513 *Deleted Section 11.0 Troubleshooting *Removed Abbreviation not used on page 4 *Updated Section 10.0 Airworthiness Limitations to latest format on page 11	05-20-22	Jeffrey R. Lowe
H	All	*Added Section 2.3 for High Utilization Inspection Program (HUIP) Time Limit for Window Shade Assembly Installations of 1600 hours, page 9	02-09-24	Jeffrey R. Lowe

## **TABLE OF CONTENTS**

<b>INSTRUCTIONS FOR CONTINUED AIRWORTHINESS</b>	<b>1</b>
<b>REVISION PAGE</b>	<b>2</b>
<b>TABLE OF CONTENTS</b>	<b>3</b>
<b>1.0 INTRODUCTION</b>	<b>5</b>
<b>2.0 INSPECTION REQUIREMENTS AND OVERHAUL SCHEDULE</b>	<b>8</b>
<b>3.0 DIMENSION AND ACCESS</b>	<b>9</b>
<b>4.0 LIFTING AND SHORING</b>	<b>9</b>
<b>5.0 LEVELING AND WEIGHING</b>	<b>9</b>
<b>6.0 TOWING AND TAXIING</b>	<b>9</b>
<b>7.0 PARKING AND MOORING</b>	<b>9</b>
<b>8.0 PLACARDS AND MARKINGS</b>	<b>10</b>
<b>9.0 SERVICE INFORMATION</b>	<b>10</b>
<b>10.0 AIRWORTHINESS LIMITATIONS</b>	<b>11</b>

## ABBREVIATIONS AND DEFINITIONS

<b>Abbreviations</b>	<b>Definitions</b>
FAA	Federal Aviation Administration
General Visual Inspection (GVI)	A visual examination of an interior or exterior area, installation or assembly to detect obvious damage, failure or irregularity. This level of inspection is made from within touching distance unless otherwise specified. A mirror may be necessary to enhance visual access to all exposed surfaces in the inspection area. This level of inspection is made under normally available lighting conditions such as daylight, hangar lighting, flashlight or droplight and may require removal or opening of access panels or doors. Stands, ladders or platforms may be required to gain proximity to the area being checked.
ICA	Instructions for Continued Airworthiness
STC	Supplemental Type Certificate

## 1.0 INTRODUCTION

The purpose of this Maintenance Manual Supplement and Instructions for Continued Airworthiness (ICA) is to provide the maintenance technician with the information necessary to ensure the continued airworthiness of the Aviation Fabricators window shade installation when installed in accordance with Aviation Fabricators design data included on STC Data List AF-513 and per Supplement Type Certificate (STC) SA01672WI.

Modifications to an aircraft obligates the operator to include the maintenance information provided by this document into the operator's aircraft Maintenance Manual and operator's aircraft scheduled maintenance program. This document defines supplementary maintenance operations and frequencies recommended by Aviation Fabricators Inc., to ensure the aircraft's airworthiness.

The information contained herein addresses the requirements specified in 14 CFR 23.1529, Instructions for Continued Airworthiness and supplements the basic Airplane Maintenance Manual only in those areas listed as pertains to the installation of the window shade assembly, as installed per the Aviation Fabricator STC Data List AF-513. For limitations and procedures not contained in this supplement, consult the basic Airplane Maintenance Manual.

### DATA

All information to support the continued airworthiness of this modification is contained in:

STC SA01672WI.  
STC Data List: AF-513.

Installation: STC Drawing List: AF-513  
Drawings D-10629 or D-10925

Parts: Refer to P/N's & respective drawings as listed on STC Data List AF-513.

The window shade assembly is a complete unit assembly that has a vertical blind assembly in it that can be raised and lowered per passenger preference. It is attached to brackets added to the existing window retainer. The new Avfab window shade replaces the existing problematic polarized windows.

### Design Change Control

All data and changes to the parts and assemblies will be tracked per STC Data List AF-513 Rev IR or later approved revision.

**Applicable Aircraft**

Beechcraft C90, C90A, C90GT, C90GTi, E90, F90, 200, 200C, 200CT, 200T, B200, B200C, B200CT, B200T, B200GT, and B200CGT Series Aircraft

Window Shade Assembly

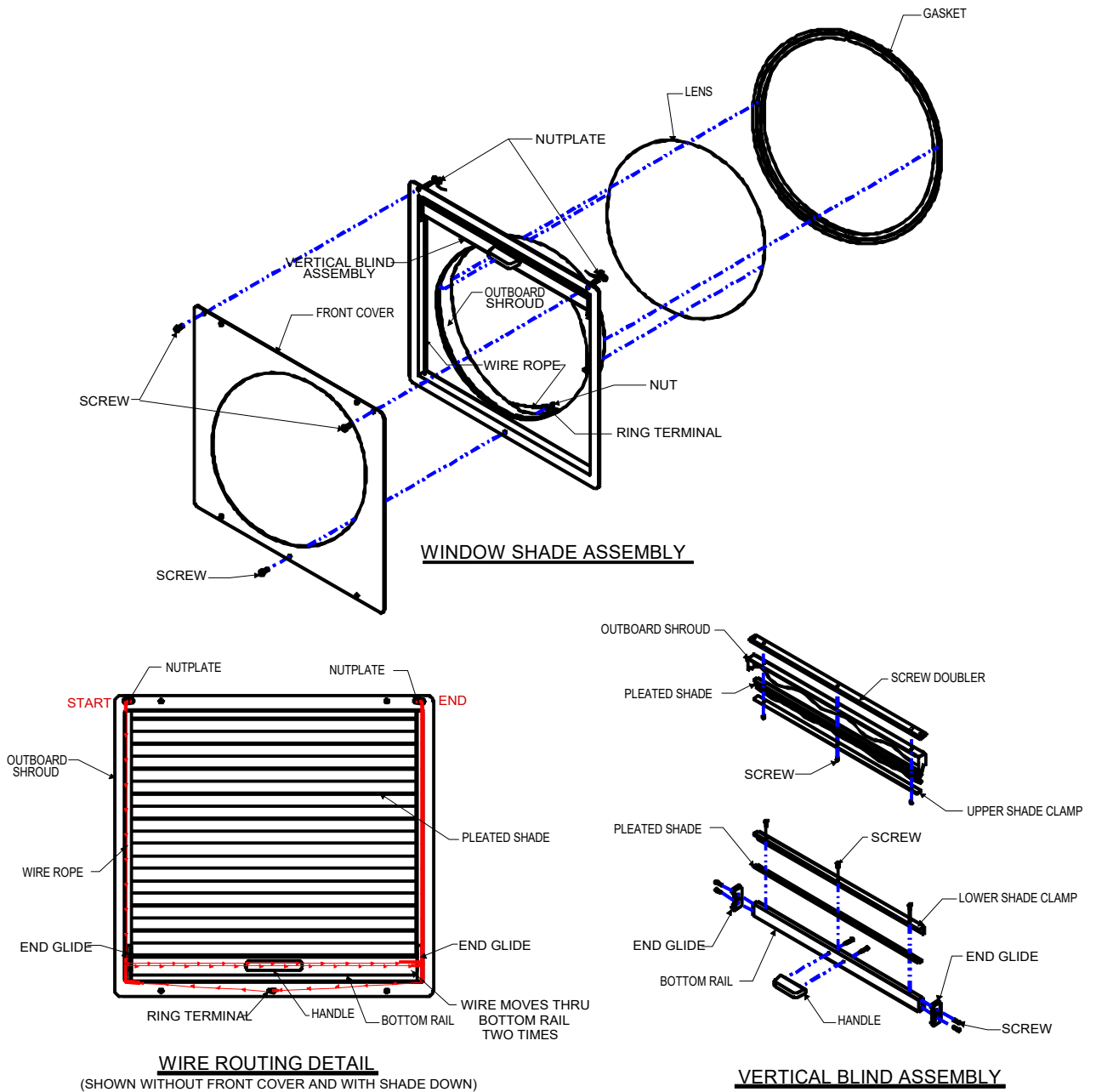

**Figure 1.0A**

Window Shade Installation

Notes for 90 Series Aircraft: The window shade can be installed on any cabin window. FS 166.90 LH & RH, FS 186.37 LH & RH, FS 206.13 LH & RH, and FS 235.43 RH

Note for 200 Series Aircraft: The window shade can be installed on any cabin window. FS 177.5 LH & RH, FS 197.5 LH & RH, FS 217.0 LH & RH, FS 236.0 LH & RH, FS 256.25 LH & RH, and FS 291.88 RH.

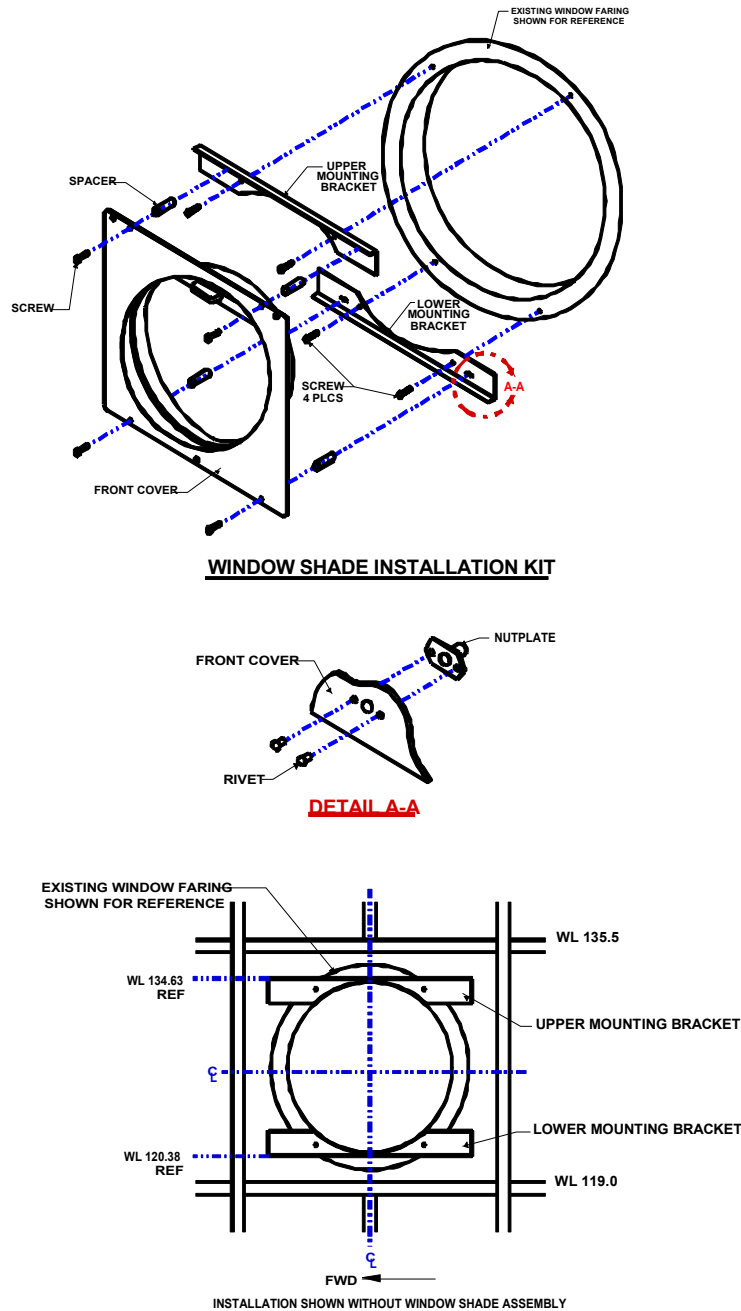

Figure 1.0B

## **2.0 INSPECTION REQUIREMENTS AND OVERHAUL SCHEDULE**

1. To comply with 14 CFR 23.1529, continue the window shade on the same inspection and maintenance schedule used per the applicable Beechcraft Maintenance Manual.
  - a. The window shade installation requires no service other than inspection at normal Phase 1, 2, 3, & 4 inspection schedule of 200 hours or 24 months whichever occurs first.
  - b. Perform a detailed visual inspection of the window shade assembly to detect apparent or obvious defects, deterioration in the form of wear, tears, rips, punctures or irregularities that cause the outboard shroud and vertical blind assembly to become worn or distorted and not function properly. If deformities are found the window shade assembly must be removed from the aircraft and returned to Aviation Fabricators for repair or replacement.
  
2. General Inspection Time Limit for Window Shade Assembly Installations:  
200 hour inspection or 24 months for the window shade assembly

<b>Task Code</b>			<b>Schedule</b>	<b>Date</b>	<b>Mech</b>	<b>Insp</b>
AFI-100	a.	Perform a General Visual Inspection (GVI) for damage to attaching points for cracks.				
AFI-101	b.	Perform a GVI of the vertical blind for wear, cuts, holes, damage, and deterioration.				
AFI-102	c.	Perform a GVI of the overall window shade for fit and function.				



3. High Utilization Inspection Program (HUIP) Time Limit for Window Shade Assembly Installations:

1600 hour inspection for the window shade assembly

<b>Task Code</b>			<b>Schedule</b>	<b>Date</b>	<b>Mech</b>	<b>Insp</b>
AFI-100	a.	Perform a General Visual Inspection (GVI) for damage to attaching points for cracks.				
AFI-101	b.	Perform a GVI of the vertical blind for wear, cuts, holes, damage, and deterioration.				
AFI-102	c.	Perform a GVI of the overall window shade for fit and function.				

**3.0 DIMENSION AND ACCESS**

No change.

**4.0 LIFTING AND SHORING**

No change.

**5.0 LEVELING AND WEIGHING**

Window Shade Assembly	= 2.25 lbs
Installation Parts	= <u>0.75 lbs</u>
Total	= 3.00 lbs

**6.0 TOWING AND TAXIING**

No change.

**7.0 PARKING AND MOORING**

No change.

## **8.0 PLACARDS AND MARKINGS**

None.

## **9.0 SERVICE INFORMATION**

### **Window Shade Service Instructions:**

#### **A. Cleaning:**

Refer to Beechcraft Maintenance Manual Section 56-00-00 for window cleaning practices.

#### **B. Maintenance Instructions:**

##### Window Shade Removal:

- a. Remove the six screws securing the window escutcheon to the service panel enclosing the window and remove the escutcheon.
- b. Remove the two retaining screws from the bottom of the service panel enclosing the window and blind assembly. The service panel is made of a rigid honeycomb core material that can be broken if subject to excessive force; this it should be removed carefully per Beechcraft MM Section 56-20-00.
- c. Remove the four screws and spacers securing the window and blind assembly to the outer window frame at the top and bottom corners of the window shroud. Remove the window and blind assembly.
- d. The window shade mounting brackets can also be removed if needed by removing the four attaching screws that attach the brackets to the outer window frame.

##### Window Shade Installation:

- a. Install mounting bracket if removed to the outer window frame using four screws.
- b. Position the window shade assembly so that the four mounting holes in the shroud align with the bracket nutplate holes and attached using four screws and spacers.
- c. Insert the top of the service panel into the upper retaining track and push it in and up until the bottom of the panel snaps into the lower retaining track.
- d. Install the two retaining screws in the lower corners of the service panel.

- e. Position the window escutcheon so that its mounting holes align with those in the service panel. Install the six retaining screws securing the escutcheon to the service panel.

### C. RECOMMENDED OVERHAUL PERIODS

No additional overhaul time limitations.

## 10.0 AIRWORTHINESS LIMITATIONS

The information contained herein supplements the basic Maintenance Manuals only in those areas listed, when the aircraft is modified in accordance with Aviation Fabricators STC Data List AF-513 Rev IR or later approved revision. For limitations and procedures not contained in this supplement, consult the basic Airplane Maintenance Manuals.

The Airworthiness Limitations section is FAA approved and specifies maintenance required under Sec. 43.16 and 91.403 of the Federal Aviation Regulations unless an alternative program has been FAA approved.

AIRWORTHINESS LIMITATIONS - LOG OF REVISIONS			
REV.	EFFECTED PAGE (s)	DESCRIPTION of REVISION	DATE
(IR)	All	Initial Release	01/10/11

### AIRWORTHINESS LIMITATIONS

There are no Airworthiness Limitations to the aircraft with the addition of the window shade assembly installed by this STC.

#### Distribution:

Per the requirement of Appendix G of 14 CFR Part 23 paragraph G23.1 (c), the changes made to the ICA by the applicant will be distributed via mail, email, or website.